

Application Note - Herringbone Mixer Fluidic 1460

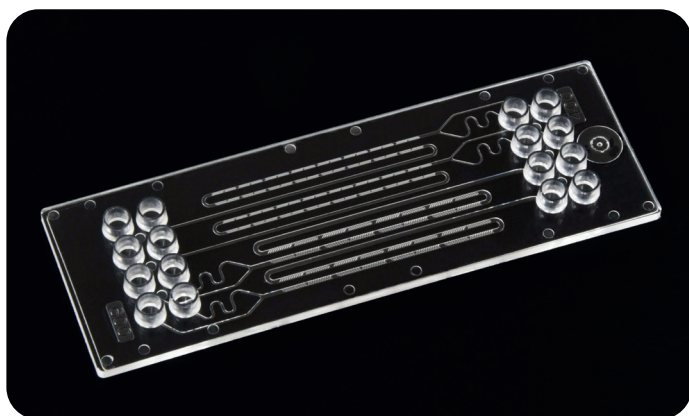
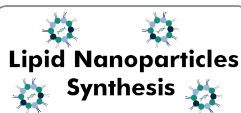

Preparation of lipid nanoparticles with microfluidics

Lipid nanoparticles (LNPs) are widely used in biomedicine as molecular drug transporters. They encapsulate small molecules, such as cancer drugs or vaccines, and deliver them to their biological target. Their advantages are that they are biocompatible, easy to produce and suitable for a variety of different targets. Historically, they have been synthesized using a standard bulk mixing method, in which large quantities of the aqueous and organic phases were mixed rapidly. However, this results in a wide size distribution and poor reproducibility. A promising alternative in the generation of LNPs is microfluidics.

We have designed the Herringbone Mixer chip Fluidic 1460 with two different channel geometries. Due to the uniformly arranged mixing structures, the synthesis of LNPs can be tailored to a defined size. This chip can be used not only for nanoparticles synthesis, but also to effectively mix two reagents.

Chip description

The Herringbone Mixer - Channel variation chip Fluidic 1460 has four functional mixing units, two of which are identical. Each unit has two inlets and one outlet, connected by a ribbed channel. These microstructures in the channels allow the mixing of different reagents. All inlets and outlets feature a Mini Luer interface.

Key features of the Herringbone Mixer - Channel variation chip - Fluidic 1460 are:

- Slide format: 75.5 x 25.5 x 1.5 mm³
- Eight inlets and four outlets in Mini Luer format
- Channel structure A:
 - Channel depth: 200 μm
 - Channel width: 600 μm
- Channel structure B:
 - Channel depth: 100 μm
 - Channel width: 400 μm

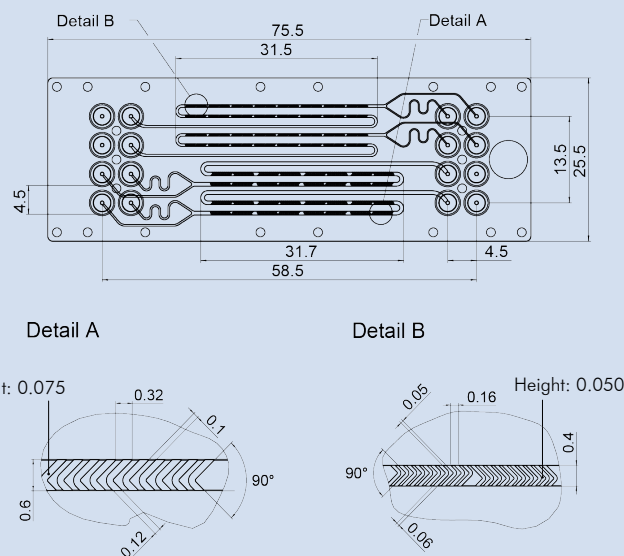

Fig.2: Structure of the chip, all dimensions are in mm

Lipid nanoparticles - Introduction

Lipid nanoparticles are used in many biomedical applications. As nanocarriers, they transport small molecules such as cancer drugs, mRNA or siRNA to their biological target. Lipid nanoparticles are taken up by cells via endocytosis. Lipid nanoparticles usually contain a structural lipid, an ionisable lipid and a polyethylene glycol (PEG) to promote cell binding. Also, cholesterol to fill the gaps between the lipids. The relative amounts of ionisable lipid, structural lipid, cholesterol and PEG significantly affect the efficacy of lipid nanoparticles and need to be optimized for a particular application and route of administration.

As a new option in the synthesis of LNPs, microfluidics increasingly come into focus. With this approach, very homogeneous particles can be produced within a short time. Microfluidics enable automation of the process and high throughput. Furthermore, a wide range of different particle sizes can be easily generated by varying the flow rate.

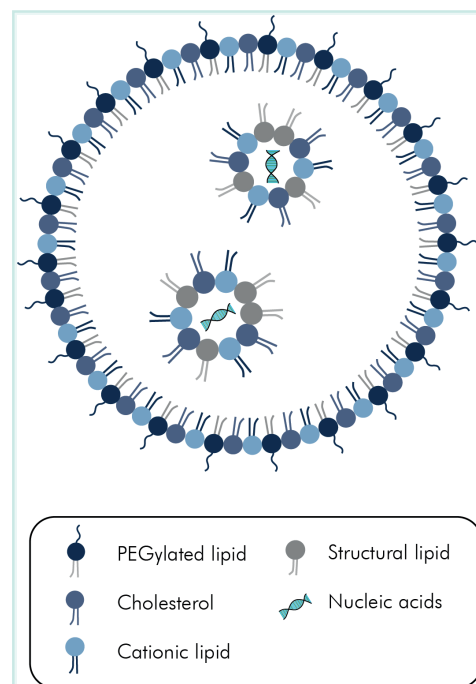

Fig.3: Structure of a LNP

Operating principle of the chip

The most important step in the generation of lipid nanoparticles is the rapid mixing of an organic and an aqueous phase. The ridged structures within the channels of the Herringbone Mixer chip mix two reagents thoroughly. The chip features two smaller and two larger mixing channel geometries that allow a wide range of experimental parameters. By connecting the chip to a pump, an even flow of the two phases can be generated. It is important to use a good quality pump here to create a pulsation-free flow. Due to the automatically based process and good mixing, LNPs are produced with a high homogeneity.

Size control of lipid nanoparticles

The particle size can be influenced by various factors:

- Chip geometry
- Flow rate
- Composition of aqueous solution
- Composition of lipid solution

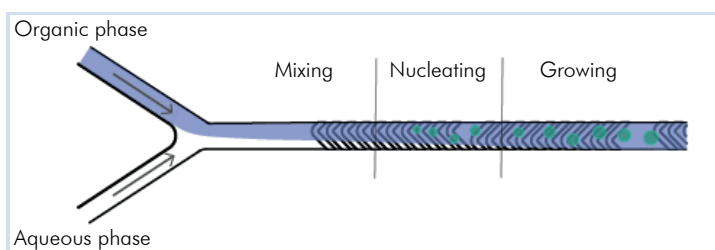

Fig.4: Stages of LNPs formation



Fig.5: Channel structures of the chip

Chip geometry

Depending on the chip geometry, the particle size varies. The Herringbone Mixer – Channel variation chip presented here can be used for the synthesis of nanoparticles with a diameter of 50 to 200 nm.

The smaller channels in Design B are better suited for lower flow rates and allow the fabrication of smaller LNPs.

Composition of the aqueous solution

The formation of the LNPs is affected by pH value and the salinity of the aqueous phase as well as the presence of surfactants. The effects of the components depend on the type of lipids used and their charge and can best be determined experimentally.

Composition of the lipid solution

The lipid formulation as well as the lipid concentration have a huge impact on the LNP size. A higher lipid concentration results in smaller LNPs. In general, the effect on the particle size depends on the lipid, the molar ratio and lipid concentration.

Flow rate

The flow rate can be described by two variables: the flow rate ratio (FRR) and the total flow rate (TFR).

Flow rate ratio is defined as the ratio between the flow rate of the aqueous phase and the flow rate of the organic phase. The higher the FRR, the smaller the particles. For example, a FRR of 10:1 will result in smaller particles than a FRR of 2:1.

Total flow rate is defined as the sum of the flow rates of both phases. A high TFR leads to a reduction of the mixing time and consequently to smaller particles. Especially with the Herringbone mixer chip, the TFR has a great influence on the LNP size, since the particle formation is mainly influenced by the mixing process.

How to generate lipid nanoparticles? - Protocol -



Together with our partner **Inside Therapeutics**, we have developed a standard protocol for the LNPs synthesis using the Herringbone Mixer - Channel variation chip. The chip and all necessary connectors are manufactured by *microfluidic ChipShop GmbH*. The pressure-driven flow controller and all associated equipment are provided by ELVEFLOW.

Materials and Methods

Material: Pressure driven pump

- OB1 flow controller
- 1x flow sensors MFS4
- 1x flow sensors MFS5
- 2x 50 ml falcon
- Computer with ESI software
- Tubing

Material: Herringbone Mixer - Channel variation chip Fluidic 1460

- Herringbone Mixer - Channel variation chip Fluidic 1460
- Mini Luer tube tuck connectors Fluidic 997
- PEEK capillary tubing (ID: 0,02", OD: 1/32")

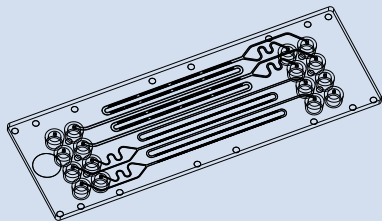

Fig.6: Schematic drawing of Herringbone Mixer Fluidic 1460 with four mixing units

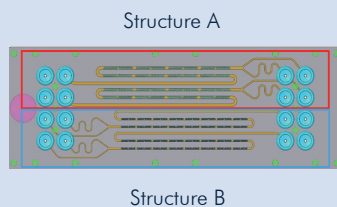

Fig.7: Technical drawing of Fluidic 1460 with structures A and B marked

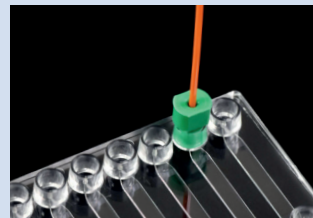

Fig.8: Mini Luer fluid connector Fluidic 997 connected to 1/32" PEEK tubing

Material: Reagents

- Lipid formulation in solvent, e.g. DSPC : Cholesterol : DOTAP : DMG-PEG2000 (10 mM) in ethanol
- Solvent, e.g. ethanol
- Aqueous solution, e.g. citrate buffer (10 mM; pH 6.0) or saline solution (9 mg/ml NaCl)

DSPC: Distearoylphosphatidylcholine

DOTAP: 1,2-Dioleoyl-3-trimethylammonium-propane

DMG-PEG2000: 1,2-Dimyristoyl-rac-glycero-3-methoxypolyethylene glycol-2000

Methods:

1. Prepare your solutions

Lipid formulation:

Prepare 10 mL of a lipid stock solution at 10 mM by adding

- 7.9 mg of DSPC
- 19.3 mg of Cholesterol
- 25.8 mg of DOTAP
- 7.5 mg of DMG-PEG2000

to 10 ml of pure ethanol and mix until all lipids are dissolved.

Then dilute the stock solution to 2 mM aliquots by mixing 2 ml of the stock solution and 8 ml of ethanol.

Aqueous solution:

Prepare the aqueous solution by dissolving

- 1.213 g of sodium citrate dihydrate
- 168 mg of citric acid

in 40 ml of ultrapure deionised water. Adjust the pH to 6 by adding NaOH or HCl. When the desired pH is reached, fill up to a volume of 50 ml with deionised water.

2. Experimental setup

The experimental setup for the LNPs synthesis is shown in Fig. 9. First, the pump setup is built as shown in the figure. The Herringbone Mixer chip is connected to the tubing via the Male Mini Luer tube tuck connector.

The entire system can be flushed with ethanol and water as your organic and your aqueous phase, respectively, to remove air from the channels and to check the system for leaks. To do this, add the ethanol or water to the reservoirs and start the pump. Once your setup is complete and leak-free, replace the reservoirs with those containing the aqueous and lipid phases. Make sure, the end of the tubes reach right down to the bottom of the reservoirs. Set the pressure of both liquids to 500 mbar until the chip is filled and liquid passes the tubing connected to the outlet. Set the flow rates of both solutions to the desired FRR and TFR. It is recommended to control the flow of both phases by the flow rate and not by the pressure as the flow rate remains constant even with small fluctuations. You can start with a flow rate of 1000 $\mu\text{l}/\text{min}$ for the aqueous phase and a flow rate of 300 $\mu\text{l}/\text{min}$ for the lipids to generate your first nanoparticles. In general, the flow rate of the aqueous solution should be equal or higher than the flow rate of the lipid formulation. The LNPs are collected in a tube. Their size can be measured directly after collection or after a cleaning step. LNPs can be purified by dialysis with 12-14 kDa MWCO (molecular weight cut-off) membranes and an aqueous buffer. This Herringbone Mixer - Channel variation chip is suitable to produce highly monodisperse lipid nanoparticles ranging from 50 to 200 nm depending on the formulation.

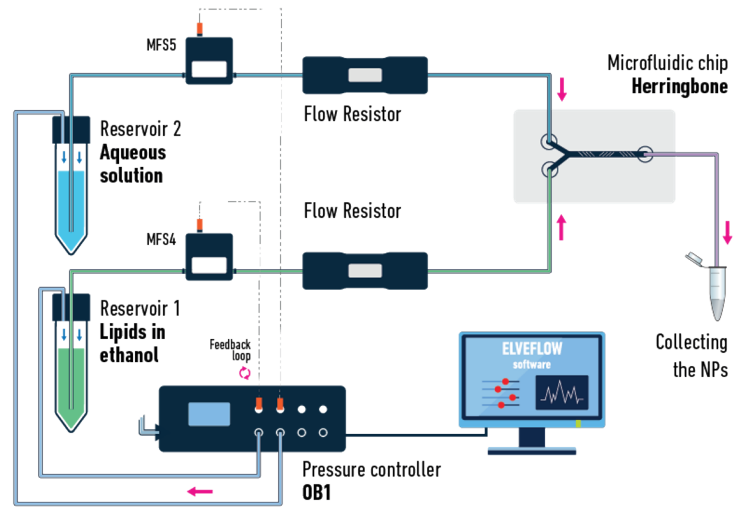

Fig. 9: Experimental setup

The larger the TFR, the smaller the particles. Similarly, the particle size decreases with increasing FRR. In structure A, larger particles can be synthesized, while structure B can be used for smaller particles. The LNPs produced have low batch-to-batch variability and a narrow size distribution with a polydispersity index (PDI) typically less than 0.2.

Application example

In the following figures, LNPs were produced at different flow rates. The larger the TFR, the smaller the particles. Similarly, the particle size decreases with increasing FRR. In structure A, larger particles can be synthesized, while structure B can be used for smaller particles. The LNPs produced have low batch-to-batch variability and a narrow size distribution with a polydispersity index (PDI) typically less than 0.2.

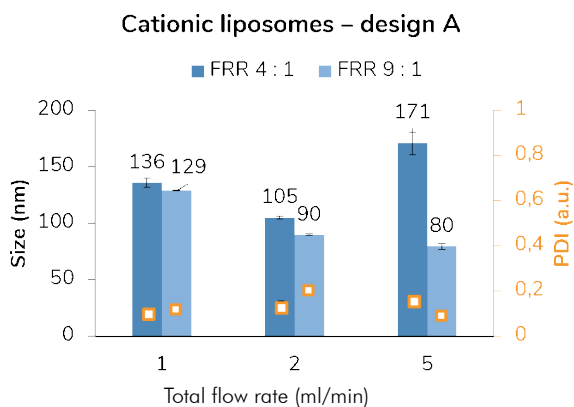

Fig. 10: Nanoparticle size as a function of TFR and FRR in structure A. Description of the size distribution by the PDI.

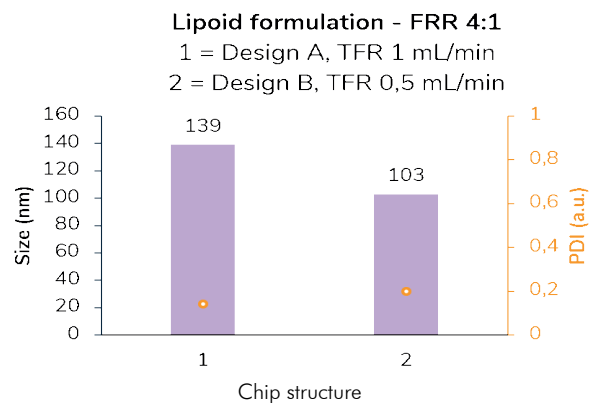

Fig. 11: Nanoparticle size as a function of chip structure. Description of the size distribution by the PDI.

Handling hacks

Avoiding air bubbles:

To reduce the formation of air bubbles, fill the tubing from the reservoir to the chip with liquid before connecting the chip. This also helps to shorten the initial filling time.

Avoiding adsorbed LNPs:

It is recommended to monitor the LNPs under a microscope. If they agglomerate or adsorb, a more hydrophilic material for the chip or a hydrophilic coating might help since the LNPs interact more strongly with hydrophobic surfaces. Tip: PC is less hydrophobic than Zeonor.

Preventing leakage:

To ensure continuous flow and uniform formation of nanoparticles, it is important that there are no leaks from the setup. The Mini Luer fluid connector or the Mini Luer tube tuck connector made of TPE are particularly recommended.

Product Code for Fluidic 1460	Description	Lid Thickness [µm]	Material	Price [€/chip]		
				1+	10+	100+
10001930	Herringbone Mixer - Channel variation	175	PC	42.20	34.40	26.10
10001931	Herringbone Mixer - Channel variation	188	Zeonor	42.20	34.40	26.10

Product Code	Description of Accessories	Material	Quantity	Price [€/chip]		
				1+	5+	10+
10000116	Male Mini Luer fluid connectors, single	TPE - Opaque	10 pcs / pack	19.00	14.00	9.40
10000205	Male Mini Luer plugs – Low volume displacement	TPE - Opaque	10 pcs / pack	19.00	14.00	9.40
10001764	Male Mini Luer tube tuck connector for 1/32" tubing	TPE - Green	10 pcs / pack	19.00	14.00	9.40
10002010	Male Mini Luer tube tuck connector for 1/16" tubing	TPE - Blue	10 pcs / pack	19.00	14.00	9.40
10000031	Silicone tube, ID: 0.76 mm, OD: 1.65 mm	Silicone	1 m	9.50		
10002009	Capillary PEEK tubing 1/32", ID: 0.50 mm, OD: 0.79mm	PEEK	3 m	91.00	15.00	12.40
10002144	Capillary PEEK tubing 1/16", ID: 0.50 mm, OD: 1.58 mm	PEEK	1.52 m	34.32		
10000043	Handling frame with high skirt	PC - orange	1pc	22.00		

microfluidic ChipShop GmbH

Stockholmer Str. 20 • 07747 Jena • Germany
 Phone: +49 (0) 3641 34705-0 • Fax: +49 (0) 3641 34705-90
inquiries@microfluidic-ChipShop.com • www.microfluidic-ChipShop.com

